

Unity™ Power Planner

POWER-GRID PLANNING FOR HIERARCHICAL CUSTOM DESIGNS

Power-grid planning for today's advanced custom designs with many levels of hierarchy and multiple power domains is a complex, often-iterated task. The primarily manual methodology traditionally used to address power planning for custom designs is time-consuming and error-prone, and does not easily accommodate the frequent changes that are inevitable during chip development. Pulsic Unity Power Planner, a breakthrough automated power-planning product created expressly for custom designs, offers a unique, streamlined methodology for power-grid planning, routing, revision, and reuse.

MANUAL APPROACHES RESULT IN DELAYS AND ERRORS

The manual planning and routing of a complex power-delivery network for an advanced custom chip is a pains-taking task; the power grid often requires modification several times during the design process. Modifications to placement and routing at any one of the many hierarchical levels of a custom design will necessitate re-routes of the power grid as well, expending valuable time and resources. Changes to one level of the power grid inevitably lead to changes at other levels, and can even necessitate changes to top-level routing and/or block placement.

To address the problem of the time and effort required to plan a power grid by hand, custom designers reuse power-grid plans from previous designs whenever possible, with respect to relative positions, metal layers and width of the power grid. However, without the ability to create and iterate power-grid designs that is possible only with automation, the power grid may be over-specified and use too much valuable chip real estate. Worse, issues can arise during integration of the top-level power grid with the power grid and signal routing for the lower level hierarchy, which can lead to costly DRC/LVS errors.

Multiple power domains, increasingly the norm for complex custom designs, present an additional challenge because manual methods offer no way to correlate the netlist for the power-delivery network with the layout. Even LVS tools may not show all the potential connectivity problems and errors.

Power Planning Flow

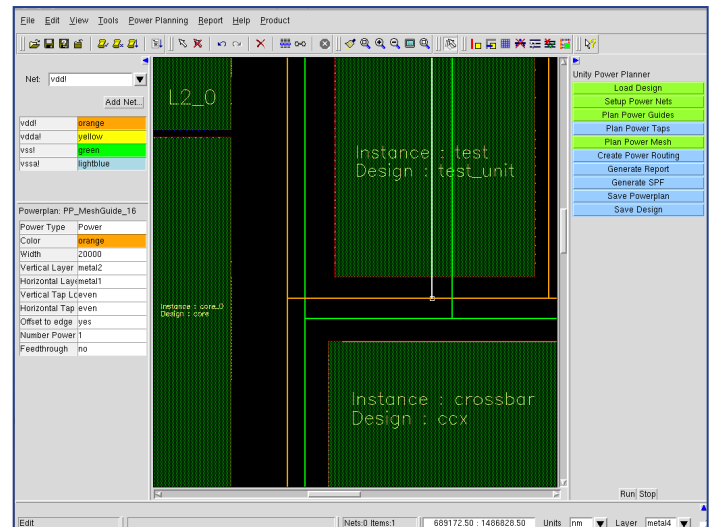
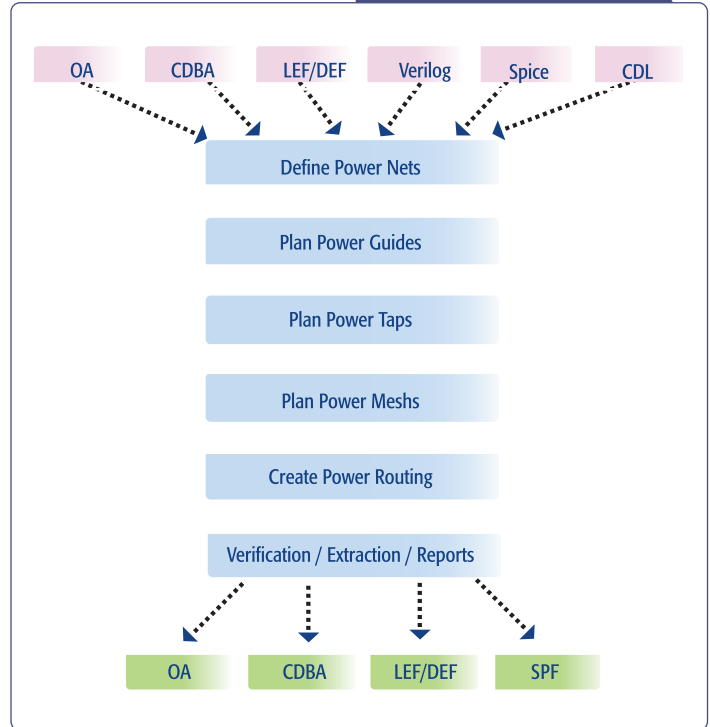

Unity Power Planner indicates how the power should be routed through the channels and to the blocks

UNITY POWER PLANNER: SPEED AND FLEXIBILITY FOR CUSTOM POWER PLANNING

Pulsic has worked closely with leading-edge, custom-design teams creating high-volume semiconductors for over 10 years. This experience has given Pulsic unique insights into the challenges of the traditional, largely manual, custom-design process, and into how to use automation to overcome these challenges.

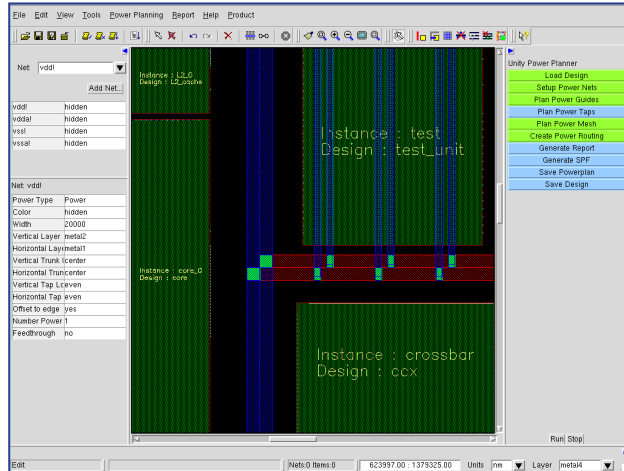

Power structures (routing and vias) created from the Unity Power Planner guides

Pulsic Unity Power Planner provides an interactive, easy-to-use, guide-driven approach to automated, hierarchical power planning that produces a power-delivery network model correlated to the layout. The Unity Power Planner methodology provides a higher level of abstraction for capturing a power-grid design using guides that are subsequently translated automatically into DRC-correct power routing and strapping when required. This approach enables designers to create complex power-routing grids supporting multiple power domains easily and quickly, and to accommodate changes rapidly throughout the design cycle. The power-planning guides created by Unity Power Planner can be saved in a power-planner file and re-used each time the netlist is changed during the lifecycle of the design.

A HIGHER LEVEL OF ABSTRACTION INCREASES PRODUCTIVITY, FLEXIBILITY AND PORTABILITY

Unity Power Planner embodies a unique methodology for power planning and routing by enabling designers to work at a higher level of abstraction, providing greater productivity, flexibility, and portability than is possible with traditional, manual approaches. With Unity Power Planner, designers interactively create hierarchical power-planning guides for all power domains at each hierarchical level by defining attributes, such as guide width, absolute/relative location, metal layer, and type of connection (soft block or hard block). Users have the flexibility to define the power-routing strategy for each level of hierarchy or block-type based upon power-grid type, matching of pre-existing power pins, a specific number of power routes and pin locations, and/or power shut-off requirements.

Unity Power Planner automatically translates these power-planning guides into power routes that correspond to the orientation, location, metal layer, and width attributes applied to the guides. Strapping is completed automatically between any two metal layers where required.

Designers can save the power-planning guide configurations in the floorplan file for later use, either to make revisions to the current netlist or for use in subsequent design projects.

BENEFITS

- Quickly explore multiple power grid implementations
- Accurately account for routing resources
- Avoid oversizing power grids to save time
- Easily accommodate multiple power grid adjustments and iterations
- Gain a high degree confidence in power grid integrity
- Eliminate 'near-tapeout' power-grid LVS issues
- Lower risk of DFM problems
- Produce early SPEF parasitics for IR voltage-drop analysis

FEATURES

- Automated generation of power-delivery networks for multiple power domains
- Power-planning guides provide a higher level of abstraction and productivity
- User-defined attributes applied to each net and/or guide for easy-to-create power grids, meshes, or custom power routing for soft blocks, hard blocks and standard/multi-height cell areas
- Automatic generation of power routing based on attributes applied to each power-planning guide
- Power-planning guides easily accommodate revisions and facilitate reuse of a power grid in a new design

SPECIFICATIONS/SYSTEM REQUIREMENTS

- Linux: x86 and x86_64
- Solaris: Sparc 64 and x86_64

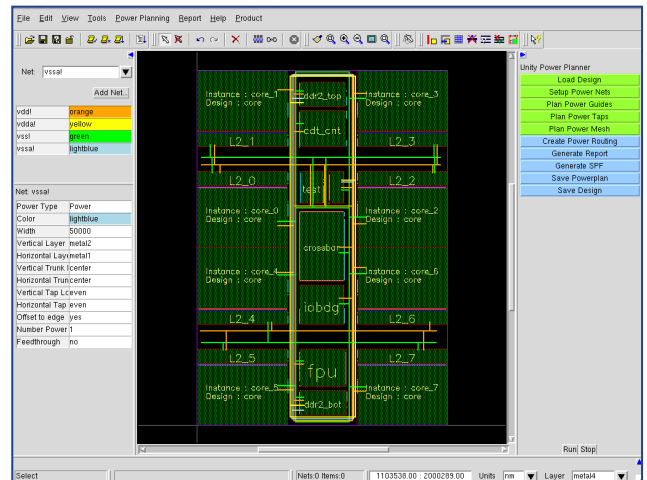

Unity Power Planner developed guides for a full chip power plan

for more information, please go to our website at www.pulsic.com or email us at sales@pulsic.com

